



OWNER'S MANUAL

2012 YETI BIG TOP

YETI CYCLES

600 Corporate Circle, Unit D
Golden, CO 80401
888.576.9384

www.yeticycles.com



TABLE OF CONTENTS

BRAND OVERVIEW	06
FRAME FEATURES	08
GEOMETRY	10
MAINTENANCE SCHEDULE	12
<i>SETUP</i>	
CABLE SETUP	14
<i>TECHNICAL</i>	
DROPOUT OVERVIEW	16
CHIP SYSTEM	17
SINGLE SPEED DROPOUTS	18
<i>LEGAL</i>	
WARRANTY	20
CONTACT INFORMATION	21

CONGRATULATIONS ON YOUR PURCHASE OF A NEW YETI.

We are confident your new bicycle will exceed your expectations for value, performance, and ride quality. Each frameset and component has been custom specified and designed to enhance your riding experience. Whether you are a beginner cyclist, or a seasoned pro, your Yeti bicycle will provide endless hours of two-wheeled fun.

This model specific manual is designed to be used in conjunction with the general Yeti Owner's Manual and the manuals supplied by the suspension manufactures. If you did not receive the Yeti owner's manual or the manual provided by the suspension manufacturer download the materials off the Internet, or contact your local dealer.

Bicycling can be a hazardous activity even under the best of circumstances. Proper maintenance of your bicycle is your responsibility and when done properly helps reduce the risk of injury and damage to your bicycle.

Warning: Make sure you review and understand the warnings, instructions, and content of this manual and accompanying manuals for your bicycle.

Warning: Technological advances have made bicycles and bicycle components more complex and the pace of innovation is increasing. It is impossible for this manual or the accompanying manuals to provide all the information required to properly repair and/or maintain your bicycle. In order to help minimize the chances of an injury, it is critical for you to have work performed by an authorized Yeti retailer.

This manual outlines basic setup and maintenance recommendations of your new Yeti. Because it is impossible to anticipate every situation or condition that may occur during the assembly, setup, and maintenance of your bicycle, Yeti recommends that all service and repairs be performed by your local authorized Yeti Dealer.

This manual contains many "Warnings" and "Cautions" concerning the consequences of failure to maintain or inspect your bicycle. The word "Warning" indicates a potentially hazardous situation in which, if not avoided, could result in serious injury or death. The word "Caution" indicates a potentially hazardous situation in which, if not avoided may result in minor injuries or damage to your bicycle or a component of your bicycle. Be sure to read and understand all of the Warnings and Cautions listed in the manual.

A 29'R HARDTAIL WITH A TRUE YETI FEEL.

1. YETI PURE TUBING
2. ISCG 05' MOUNT
3. CARBON FIBER REAR TRIANGLE
4. TAPERED INSET HEADTUBE (44MM/56MM)
5. DIRECT MOUNT FRONT DERAILLEUR
6. DROPOUTS 12MM X 142 THRU AXLE OR 135MM QR
7. SINGLE SPEED COMPATIBLE

1. The Big Top's front triangle is constructed with custom butted and tapered 7005 aluminum Yeti pure tubing. This makes the frame lightweight and strong without the use of gussets. The unique shape perfectly compliments the shape of the headtube for increased front-end stiffness.
2. Set up and run a 1x10 drivetrain with a chain guide cleanly and efficiently with the removable ISCG 05' tab. The tabs are lighter than a welded version and they are easily removable when running a traditional 2x10 or 3x10 drivetrain.
3. The high modulus carbon fiber rear triangle keeps the frame laterally stiff while providing a more forgiving ride on rougher terrain.
4. Using our new inset headtube on the Big Top allows for a larger headtube with more welding area, increased stiffness, and lower overall ride height.
5. Mount a Shimano Direct Mount D Type or Sram High Direct Mount front derailleur to the Big Top with ease.
6. The Yeti chip system allows for an easy switch between a standard 135mm QR or the 142mm x 12mm Shimano thru-axle system.
7. Run your Big Top 29'R as a single speed with a set of single speed drops. The chainstay length is adjustable from 17.3" to 18.0".

GEOMETRY

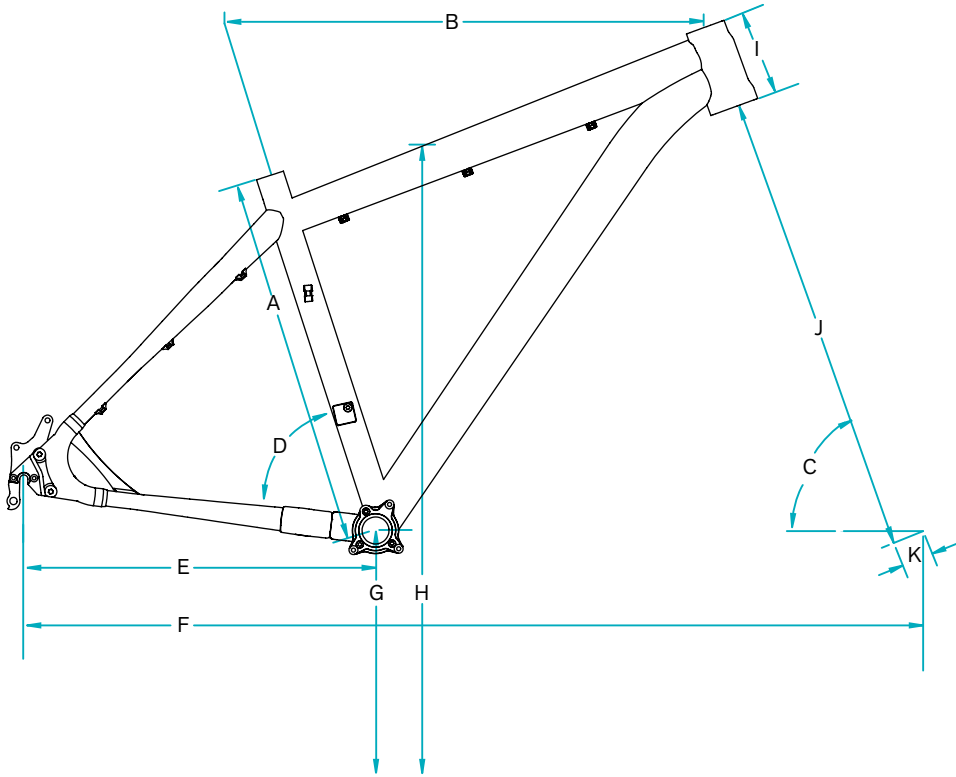

100 MM FORK

	SM	MD	LG
A	18.0	19.5	21.0
B	23.5	24.8	25.8
C	70.0	70.0	70.0
D	72.0	72.0	72.0
E	17.1	17.1	17.1
F	43.0	44.3	45.3
G	12.0	12.0	12.0
H	31.0	32.0	33.0
I	4.1	4.9	5.5
J	19.7	19.7	19.7
K	1.7	1.7	1.7

**All measurements are in inches*

FIT

- MEDIUM** 5'7" (170 CM) - 5'10" (178 CM)
- LARGE** 5'11" (180 CM) - 6'2" (188 CM)
- X-LARGE** 6'3" (190 CM) - 6'6" (198 CM)

KEEP YOUR NEW YETI FRESH AND CLEAN

OVERVIEW

Following these guidelines will help maintain the performance of your bicycle and prevent more serious problems from arising. It is important to remember that service intervals can vary depending on climate, trail conditions and riding frequency. If you are unsure about working on your own bicycle, contact your authorized Yeti Dealer or visit the repair help section at www.parktool.com for more information on general bicycle maintenance.

SCHEDULE

	WEEKLY	MONTHLY	3 MONTHS	ANNUALLY
CLEAN AND LUBE CHAIN	■			
CHECK TIRE PRESSURE	■			
CLEAN BIKE OF MUD AND DEBRIS	■			
CHECK BRAKE FUNCTION	■			
CHECK SHOCK PRESSURE, IF APPLICABLE	■			
CHECK FOR LOOSE BOLTS AND TIGHTEN, IF NECESSARY	■			
CHECK HEADSET AND TIGHTEN / LOOSEN, IF NECESSARY		■		
THOROUGHLY CLEAN PIVOT POINTS WITH A RAG (DO NOT LUBRICATE)		■		
REPLACE BRAKE PADS, IF NECESSARY			■	
CHECK TIRES FOR WEAR			■	
CHECK SPOKE TENSION AND RETENTION, IF NECESSARY			■	
CHECK CHAIN FOR WEAR AND REPLACE IF NECESSARY			■	
COMPLETE TUNE-UP PERFORMED BY AN AUTHORIZED YETI DEALER				■

CABLE SETUP

YETI TIPS

The Big Top has full cable housing. By using full cable housing, we have eliminated break points in the line of your shifter housing. This allows riders to experience better overall shifting performance by reducing the entrance of unwanted elements such as sweat and sediment. Use of full cable housing helps prevent corrosion from the elements and keeps the shifting smoother for a longer period of time.

Caution: The failure to properly route shifter housing can cause malfunction of the shift mechanism and unexpected shifting of gears.



01. REAR DERAILLEUR

Fit the housing from the rear shifter across the head tube and into the cable stops on the bottom of the top tube. There are three cable stops on the bottom of the top tube, each with three positions to secure housing. Fit the rear housing line along these stops using the middle position. Next, route the housing down the drive side seat stay and loop in to the rear derailleur to finish.



02. FRONT DERAILLEUR

Fit a piece of housing from the front shifter across the head tube and into the cable stops on the bottom of the top tube. Fit the front derailleur housing along the three cable stops using the position closest to the drive side. Next, route the housing down the drive side of the seat tube. Run the housing directly into the stop on the front derailleur to finish.



03. REAR BRAKE

The rear brake line loops across the head tube and into the cable stops on the bottom of the top tube. Use the position closest to the non-drive side of the frame on the cable guides for the rear brake line. Next, route the brake line down the non-drive side seat stay and into the caliper body. Ensure the line is finished on the inside of the seatstay when attached to the caliper body. This will prevent the brake line from being compromised if the bike or rider falls.



DROPOUT SYSTEMS

YETI TIPS

Make sure your tools are in good condition. A worn allen key can round the hex on a bolt not allowing for proper torque.

Torque settings are listed throughout the instructions. It is also important to prep all bolt threads. The instructions denote whether to use a blue Loctite compound or grease.

Warning: Service on Yeti bicycles requires special knowledge and tools. Yeti Cycles recommends that all service and repairs be performed by an authorized Yeti Dealer



TOOLS NEEDED

- 5mm allen key
- 3mm allen key
- 2.5mm allen key
- Blue loctite



01. CHIP SYSTEM

Use a 2.5mm allen key to loosen the two M4x9mm flat head bolts holding the QR insert derailer hanger in place. Remove the bolts and the QR insert from the frame. Repeat the process for the bolts and the non drive QR insert.



02. CHIP SYSTEM

Fit the 12MM insert hanger into the groove on the inside of the drive side chainstay. The hanger should be flush with the chainstay. Next, insert the 12mm drive cap through the chainstay and into the hanger from the outside of the drive side chainstay. To finish, use a 3MM allen key to attach the two dropout pieces to the swingarm with two M4x15MM cap bolts. Prep the bolts with loctite and insert them into the drive cap, through the swingarm and into the hanger.



03. CHIP SYSTEM

Fit the 12MM non-drive insert into the groove on the inside of the non-drive side chainstay. The insert should be flush with the chainstay. Next, fit the non-drive 12mm cap through the chainstay and into the insert from the outside of the non-drive side chainstay. To finish, use a 2.5MM allen key to attach the two dropout pieces to the swingarm with two M4x10MM flat head bolts. Prep the bolts with loctite and insert them into the non-drive cap, through the swingarm and into the insert.



04. CHIP SYSTEM

Insert the M4x6MM custom cap bolt into the top of the drive cap. This bolt will be used to set the position of the Shimano 142x12MM axle. Refer to Shimano specifications for exact instructions on proper axle operations.

Torque for all chip system bolts: 15-20 in/lb





01. SINGLE SPEED DROPS

Use a 5mm allen key to loosen the two M8x17mm bolts holding the standard drive side Big Top dropout in place. Remove the bolts and the dropout from the frame. Repeat the process for the bolts and drop out on the non-drive side.



02. SINGLE SPEED DROPS

Fit a dropout insert into each of the two grooves on the inside of the drive side single speed drop. Next, slide the drive side mount over the two inserts and into the dropout. This assembly fits flush onto the inside of the drive side chain stay.



05. SINGLE SPEED DROPS

Tighten the two M6 shoulder bolts on the drive side dropout with a 5mm allen key. Repeat the process for the non-drive side.

Torque to 70-75 in/lb.



06. SINGLE SPEED DROPS

Double check that the dropouts are square and the rear wheel is centered in the frame. When assembling the Big Top as a single speed for the first time it will be helpful to set the chain stay to the desired length before measuring and cutting the chain. This will help ensure proper chain tension for the bicycle. When making a large adjustment of the chain stay length after the bicycle is assembled be aware that a change to the chains length may be necessary.



03. SINGLE SPEED DROPS

Attach the assembly from step number two to the frame with two M6 shoulder bolts prepped with washers and blue loctite. Use a dropout plate between the bolts and the outside of the chain stay. Tighten the bolts so that the dropout can still slide on the mount, they will be torqued to spec later in the assembly. Repeat steps two and three for the non-drive side components.



04. SINGLE SPEED DROPS

Place the rear wheel in the dropouts and slide the drops to the desired chain stay length (17.3" to 18.0"). Install a M5x50mm cap bolt with a M5 jam nut into each drop out. Adjust these bolts with a 4mm allen key to ensure both dropouts are square, the rear wheel is centered in the frame, and chain tension is correct. Lock the cap bolts in place by tightening the jam nuts against each dropout.

WARRANTY

YETI LIMITED (1) ONE YEAR FRAME WARRANTY

(applies to 303 WC / 4X / DJ)

Yeti Cycles will repair or replace, at its option, any frame it determines to be defective due to defective materials and/or workmanship. The (1) one year limited warranty is conditioned upon the bicycle being ridden under normal conditions and having been properly maintained. This warranty does not apply to the components attached to the frameset such as suspension components, wheels, drive train, brakes, seatpost, handlebar and stem. This warranty applies only to the original owner and is non-transferable. This warranty is void if the bicycle was not properly assembled by an authorized Yeti dealer.

YETI LIMITED (2) TWO YEAR FRAME WARRANTY

(applies to AS-R 5C / AS-R 5A / AS-R Carbon / SB66-A / SB66-C / SB95 / 575 / ARC / Big Top 29'R)

Yeti Cycles will repair or replace, at its option, any frame it determines to be defective due to defective materials and/or workmanship. The (2) two year limited warranty is conditioned upon the bicycle being ridden under normal conditions and having been properly maintained. This warranty does not apply to the components attached to the frameset such as suspension components, wheels, drive train, brakes, seatpost, handlebar and stem. This warranty applies only to the original owner and is non-transferable. This warranty is void if the bicycle was not properly assembled by an authorized Yeti dealer.

ADDITIONAL CONDITIONS

These limited warranties do not apply to normal wear and tear, nor to claimed defects, malfunctions or failures that result from abuse, neglect, improper assembly, improper maintenance, alteration, collision, crash or misuse. The original owner shall pay all labor charges connected with the repair or removal of all components. Under no circumstance does this limited warranty include the cost of travel or shipment to and from an authorized Yeti dealer. In order to exercise your rights under these limited warranties, the bicycle or frameset must be presented to an authorized Yeti dealer, together with proof of purchase.

**The above warranties have been in effect since January 2012. For warranty information on Yeti frames sold prior to that date please consult your local authorized dealer.*

NO FAULT REPLACEMENT POLICY

Yeti Cycles will make replacement parts available at a minimum charge to the original owner in the event of a crash or any other non-warranty situation. Yeti Cycles does this at its sole discretion and reserves the right to refuse this offer.

PRODUCT LIFE CYCLE

Every YETI frameset has a useful product life cycle. The length of that useful product life cycle will vary depending on the construction and the materials of the frameset, maintenance and care the frameset receives, and the amount and type of use the frameset is subjected to over its life. YETI recommends that an authorized YETI dealer should inspect the frame for stress annually. Frame stress could cause potential failure and the signs are usually apparent in the form of cracks, fracture lines, deformation, dents, and any other visual indicators of abnormality. These safety checks for frame stress are important to prevent accidents, injury to the cyclist, and product failure of a YETI frameset.

DISCLAIMER

YETI Cycles is not responsible for any damages to you or others arising from riding, transporting or other use of your bicycle. In the event that your frame breaks or malfunctions, YETI Cycles shall have no liability or obligation beyond the repair or replacement of your frame pursuant to the terms outlined in the warranty.

**If you have a warranty concern, please contact your authorized Yeti dealer.*

YETI CYCLES

600 Corporate Circle, Unit D
Golden, CO 80401
(p) 303-278-6909
(f) 303-278-6906
www.yeticycles.com

BUSINESS HOURS

Monday-Friday
8AM-11:30AM, 1:00PM-5:30PM
(Mountain Time)